

GTH SERIES

PARALLEL TWIN-SPINDLE CNC TURNING CENTERS



THE ULTIMATE MACHINING POWER
WOODWAY

PARALLEL TWIN-SPINDLE CNC TURNING CENTERS

From high efficiency production demand for automobile industry, the GTH series CNC turning center with advanced parallel twin spindles, twin turrets structure and high efficiency automation system, the GTH provides automatic loading, front/rear cutting, unloading and work-piece detecting, which make its ultimate machining capabilities a coordinated process. Furthermore, the GTH series fulfills all types of plate-shape and short-shaft work-piece of automatic mass production needs.



Revolutionary Parallel Twin-spindle Structure Design

Excellent Expandability

Low mechanical interference, easy to integrated twin spindles machine, single spindle machine and all types of automatic system into a highly efficient production line.

More Flexible Process Arrangement

Assist by robot arm and flipping device, the twin spindles design can provide front/rear cutting simultaneously but also front cutting simultaneously to meet the best process arrangement of mass production.

Higher Unit Area Production Output Value

Compare to normal twin spindles turning center, GTH is more compact and smaller floor space.

Loading by robot arm on 2nd spindle increase the working efficiency more than 5 times base on twin spindles simultaneous receiving design, shorten non-cutting time.

By optimized production line layout, leading quality and mass production capabilities to an unprecedented level



Tailor-made Production Line Available

For different application needs, GOODWAY R&D team with rich experience of Turn-Key cases and precise process analysis program, can integrated GTH series, automation system and work-piece detector optimized configuration to achieve ultra-high mass production capacity while ensuring stable product accuracy.



Double Machines + Double Robot Arm



Single Machine + Single Robot Arm
(w /work-piece cleaning and detecting device)



Single Machine + Single Robot Arm



(GTH-2000 model shown with optional accessories.)

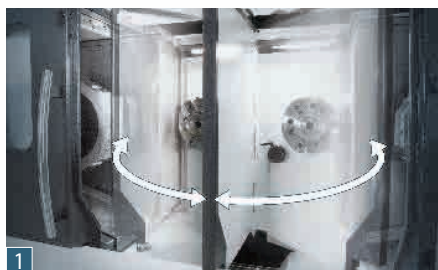

1 Safety Maintenance

- ▶ Movable protection door between two spindles which can prevent chips contamination of another processing area.
- ▶ When the machine is not running, operator can rotate the movable protection door to increase the space of operation.



2 3 Chip Removal

- ▶ Optimized chip removal design, chips can easily fall into chip conveyor and quickly take away from the processing area.
- ▶ Rear discharge chip conveyor makes GTH production line more compact. It is not only improves the utilization rate of factory space, but also good to achieve central chip conveyor belt design.



SUPER RIGID STRUCTURE

By using Finite Element Analysis (FEA) and high tension Meehanite casting structure, super rigidity frame of spindles, turrets and saddle are reaching the optimal reinforcement. Mechanical strength is well enough to load extremely heavy cutting while maintaining long period of super high accuracy. Moreover, super rigidity of machine can extend life time of tools.

Independant Twin Base Design

It can efficiently decrease cutting resonance of two spindles systems and increase reliability of machining, roundness and roughness of appearance.

Ensure the single spindle model or twin spindles models can be flexibly provided under the conditions of high rigidity structural design to meet the configuration requirements of various production lines.



Single spindle model

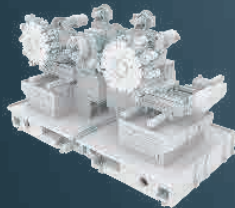

Twin spindle model

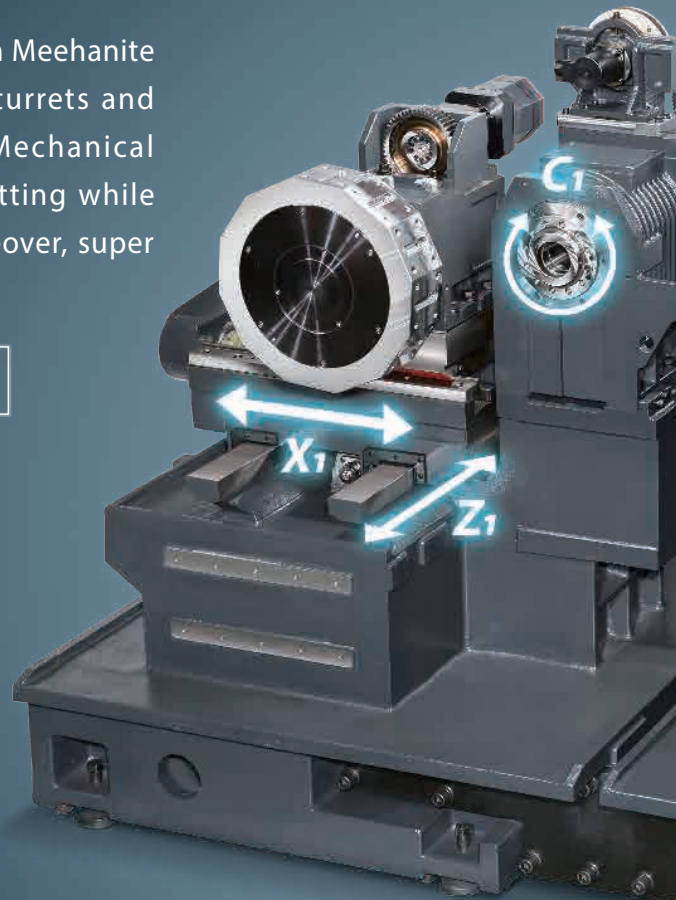

(Casting structure of GTH-2000 model shown.)

Varies Applications

1 Line tact time 40 sec. / work-piece

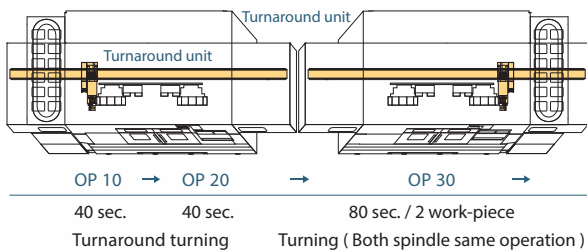

3 Line tact time 40 sec. / work-piece

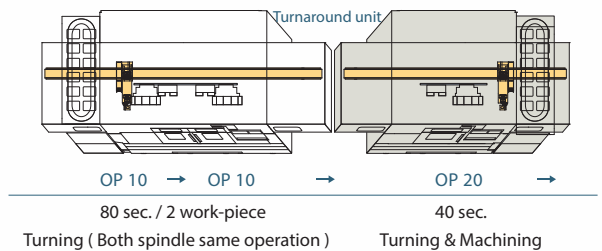

2 Line tact time 40 sec. / work-piece

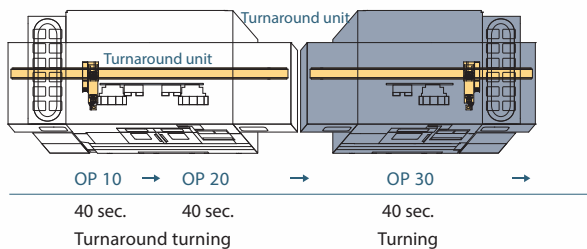

4 Line tact time 40 sec. / work-piece

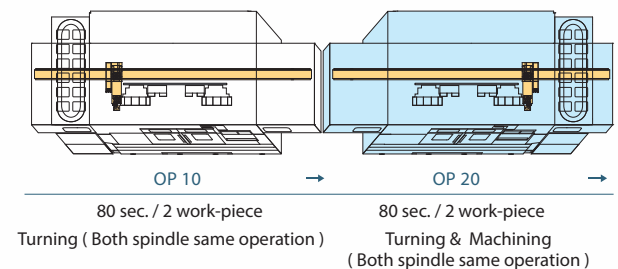

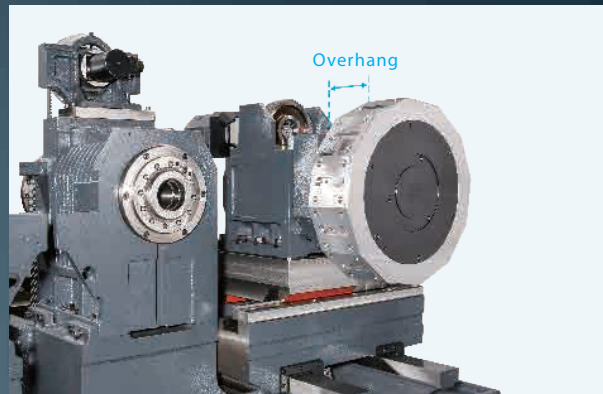
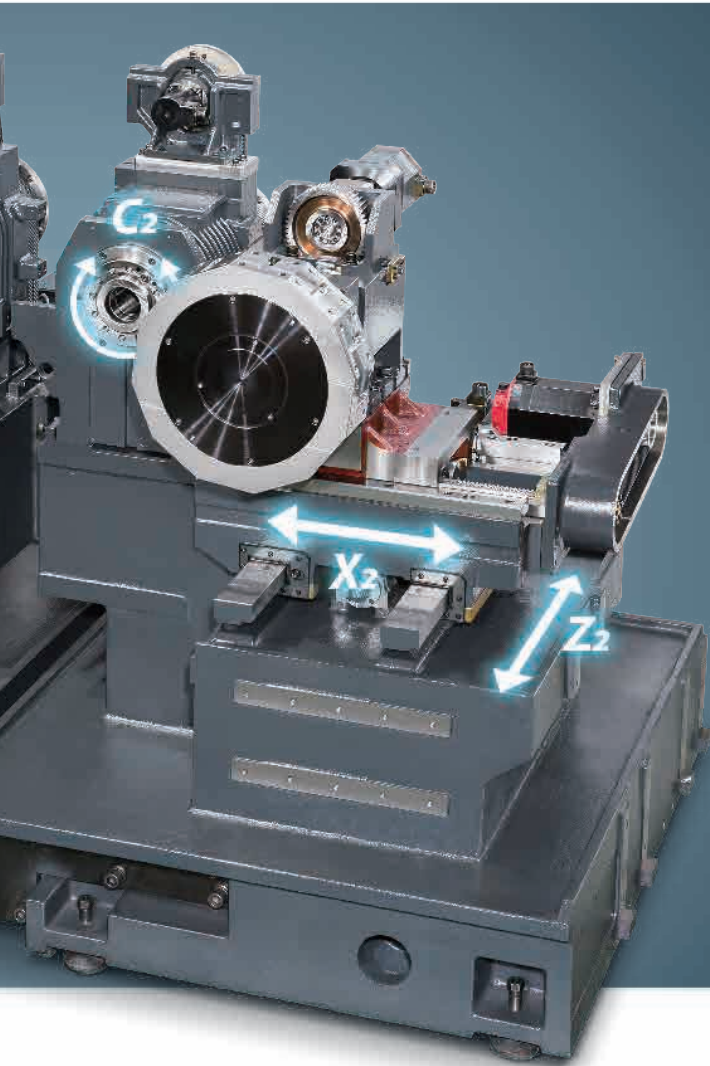

- ▶ Full travel of saddle and turret are firmly supported by bed, and distance of overhang of turret is shorter which increase cutting rigidity.
- ▶ X / Z axes adopt super rigidity box ways design which is through heat treatment and precise finishing processes. And long span design of traverse can maximize strength and precision.
- ▶ Contact surfaces of all slides, headstock, turret, and ball screw bearing housings with the machine bed are precision hand scraped to provide maximum assembly precision, structural rigidity, and load distribution.

5 Line tact time 40 sec. / work-piece

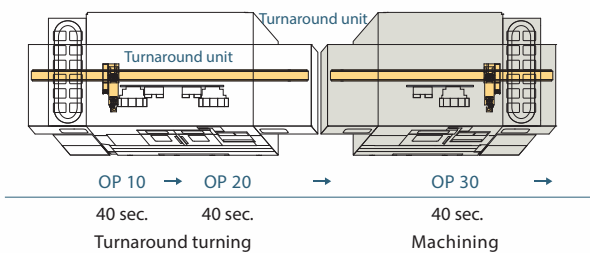

7 Line tact time 40 sec. / work-piece

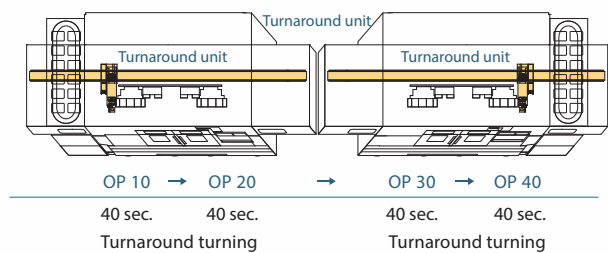

6 Line tact time 40 sec. / work-piece

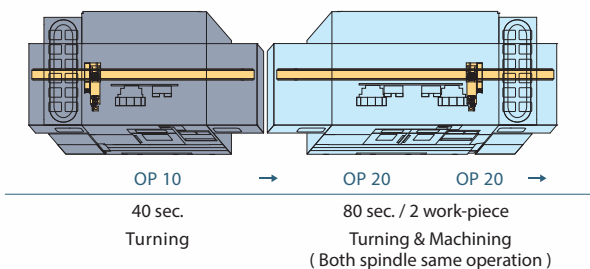

8

Line tact time 40 sec. / work-piece

160 sec. / 2 work-piece OP 10 OP 10 →
 Turning (Both spindle same operation)

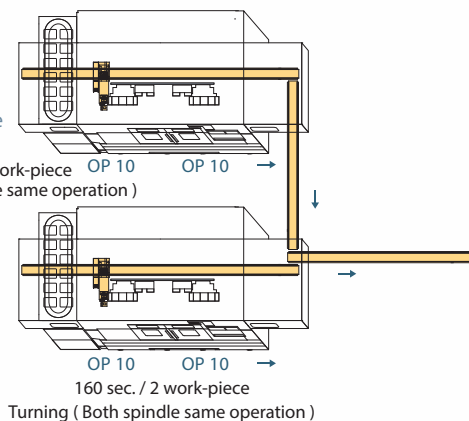

ULTIMATE MACHINING POWER

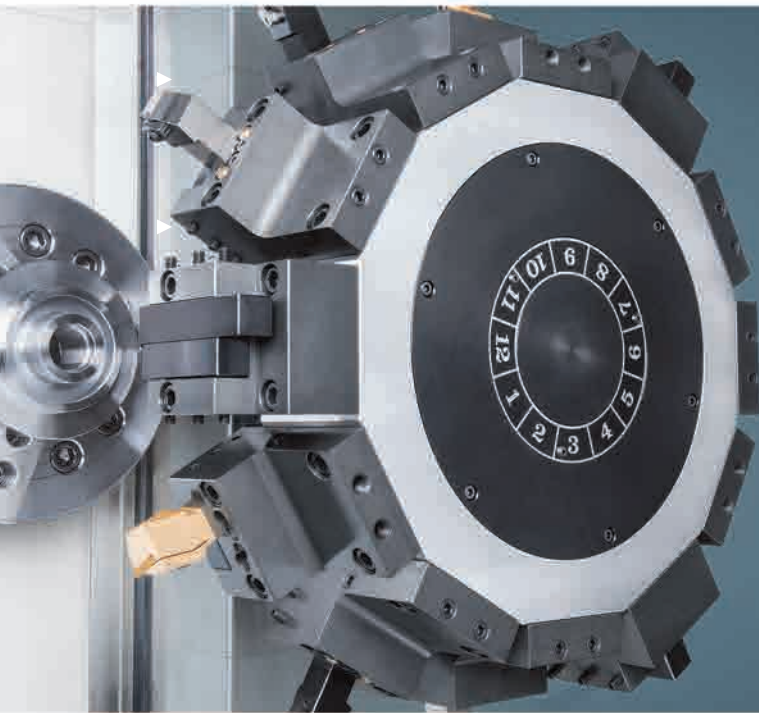

High Performance Servo Indexing Turret

- ▶ Heavy-duty servo indexing turret achieves 0.2 second indexing times for adjacent stations and 0.5 second times for stations at the opposite end of the disk turret.
- ▶ Ø 210 mm (8.26") diameter super high precision CURVIC couplings accurately position the turret disk (± 2 sec. of arc) and 4,000 Kg of clamping force ensures abundant turret rigidity for all cutting conditions.
- ▶ The CURVIC coupling is provided with automatic centering, cleaning and super large contact area of tooth flank, which ensures long-term usage of cutting rigidity and positioning accuracy.

Curvic Coupling



Concave



Convex

High Power Spindle

- ▶ The precision direct belt drive system provides greater spindle control, flexibility and serviceability.
- ▶ The 4,000 rpm high torque spindle is equipped with a powerful 15 kW (30 min.) wide-range motor that generating twice the torque output of standard motors.
- ▶ P4 grade (Class 7) super-high precision bearings are directly assembled for maximum level of support and precision. Bearing configuration is designed for super heavy-duty cutting with ultra-smooth performance and long term durability with a higher level of accuracy.

Spindle Output

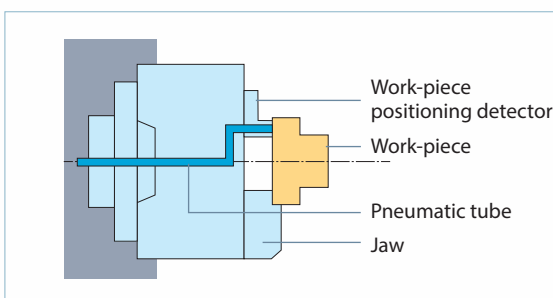
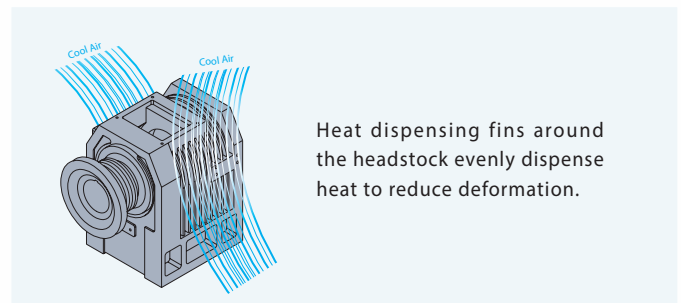
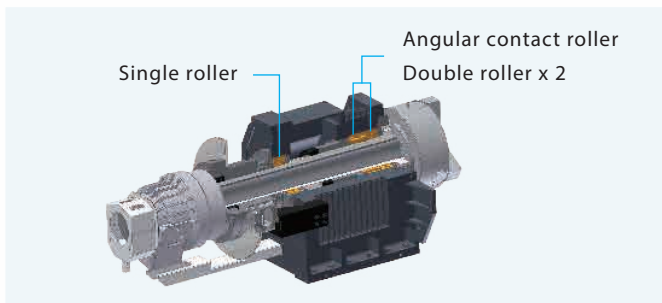
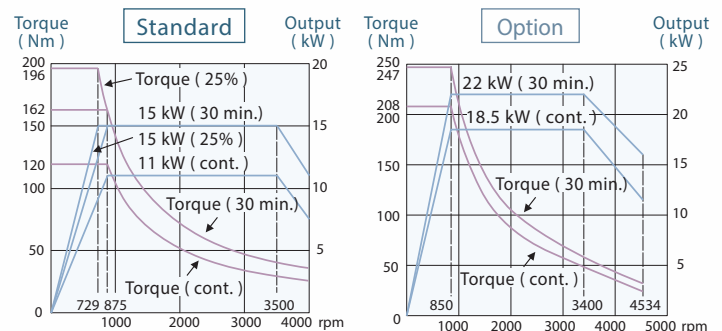

Pneumatic Work-Piece Positioning Detector

Option

Apply pneumatic flow to detect work-piece and fit of clamping jaw surface. When not adjust closely to fit, robot arm will re-load again to ensure operation safety.

LIVE TOOLING TURRET Option

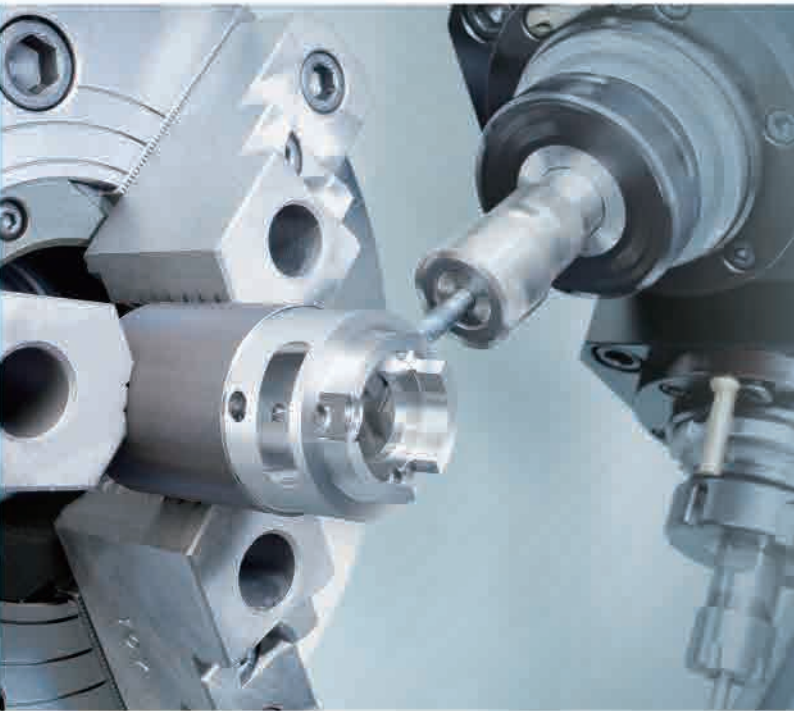

Live Tooling Turret & C-axis

▶ Working with the live tooling turret, the Cf-axis and disk brake system enables the machine to perform multiple tasks, such as drilling, tapping, and milling operations, including cylindrical and polar coordinate interpolations, resembling a 4th-axis rotary table on a machining center.

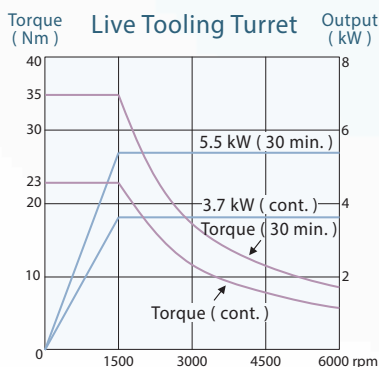
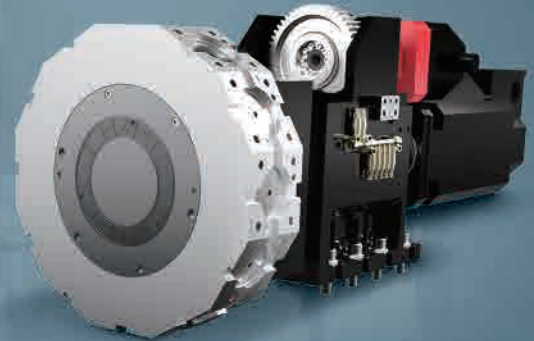

- ▶ The 12-station (Opt. 16) GOODWAY live tooling turret offers 12 (16) stations available for live tooling (live tooling tools rotate in working position only).
- ▶ With the latest technology, live tooling is driven by an AC servo motor to provide ample power, in the form of torque. Now, even the toughest of jobs may be tackled without a sweat.
- ▶ The FANUC Cf-axis servo motor generating an ultra-high resolution of 33,000,000 pulses per spindle rotation and high output torque, machined surface finishes are much superior. Also, dynamic accuracy is within $\pm 0.02^\circ$ even under heavy cutting loads.

NC INTELLIGENCE **G.LINC 350** Option

The new generation of G.LINC intelligent HMI system is with faster hardware, operating systems and more powerful software. We have a breakthrough technology and ideas to build the G.LINC, it is ready to work with you into the next generation of intelligent manufacturing.



Comprehensive Functions

Programming	Setting	Test-Run	Actual Production	Daily Used
Dynamic graphic display Program management Friendly programing environment Programming auxiliary Manual Guide <i>i</i> Embedded E-manual	3D advance tool path and cutting simulation	Tool load monitor Program check Smart balance etection 3D Real-time cutting simulation Interference check (31 <i>i</i> option needed)	Tool load monitor 3D Real-time cutting simulation Interference check (31 <i>i</i> option needed) Load monitoring	Safety signal viewer Fast alarm check productivity Productivity management Twin operation system switch Maintenance management NFC apply authority management and record

AUTOMATION SYSTEM

GOODWAY supply various flexible automatic system according to different specification of work-piece and processing characteristics to meet your high efficiency and low manpower requirements.

High Performance Gantry Type Loading / Unloading System

- ▶ Abnormal load automatic detection and stop all axes movement.
- ▶ Allow restart from the interrupted position.
- ▶ Auto unload current work-piece if pneumatic work-piece positioning detector under NG status while loading*

* Optional pneumatic work-piece positioning detector is required.

X-axis Rapids | **2,500 (mm/sec.)**

Gantry type loading / unloading system		I	II (opt.)	III (opt.)
Loader work-piece handling capacity (weight)		3 kg x 2	6 kg x 2	8 kg x 2
Loader work-piece handling capacity (size)		Ø 150 x 80 mm	Ø 200 x 60 mm	Ø 250 x 60 mm
X-axis (Left / Right)	Stroke	4,200 mm*1		
	Max. speed	2,500 mm/sec.	2,000 mm/sec.	2,000 mm/sec.
Y-axis (Up / Down)	Stroke	800 mm		
	Max. speed	2,000 mm/sec.	1,500 mm/sec.	1,500 mm/sec.
Z-axis (Front / Rear)	Stroke	210 mm		
	Max. speed	750 mm/sec.		
C-axis	Stroke	180°		
	Max. speed	1 sec./180°		
Repeatability		±0.1 mm		
Jaw rotation		Pneumatic rotation module		
Jaw (robot arm)		3-jaw (Ø20mm)	3-jaw (Ø20mm)	3-jaw (Ø26mm)
Jaw (flipping device)		3-jaw (Ø20mm)	3-jaw (Ø20mm)	3-jaw (Ø26mm)

*1 Stroke varies from requirements.

Standard stocker	I	II (opt.)	III (opt.)
Number of pallets	12	10	10
Max. work-piece diameter	Ø 150 mm	Ø 200 mm	Ø 250 mm
Stack height	350 mm	350 mm	350 mm
Weight of work-piece / pallet	40 kg	50 kg	50 kg

Specifications are subject to change without notice.



2 1st spindle unloading / loading



1 Work-piece clamping

Standard Stocker

Optional 10 / 12 sets of pallets by various fixing way to meets all kinds of machining requirement.

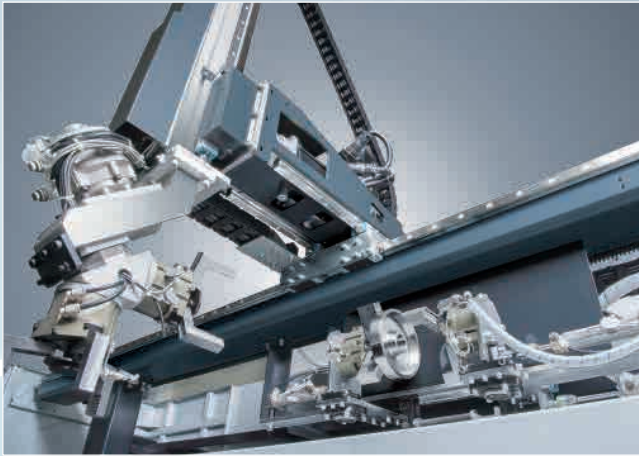

3 Flipping work-piece

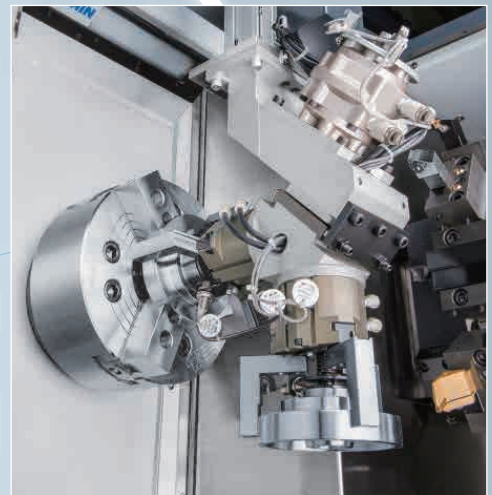

4 2nd spindle unloading / loading

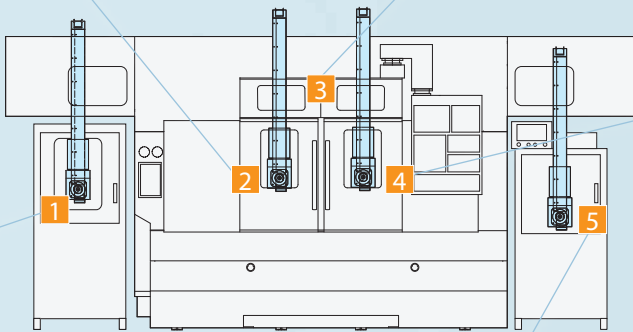

Rotary Twin Jaws Robot Arm

Programmable 3 axes robot arm with rotary twin jaws design, loading/unloading can be done by one robot arm. Fast, safe and simple to operate.



5 Work-piece detection / unloading

Accuracy Detection Device

By using 0.4 μm high resolution Eddy-current testing technology which measure by relative distance without touching the surface can accurate detect work-piece accuracy. Multiple advantages, such as high reliability, high detection rate and zero wear.

GENERAL DIMENSION

Interference Diagram 12-Station Turret

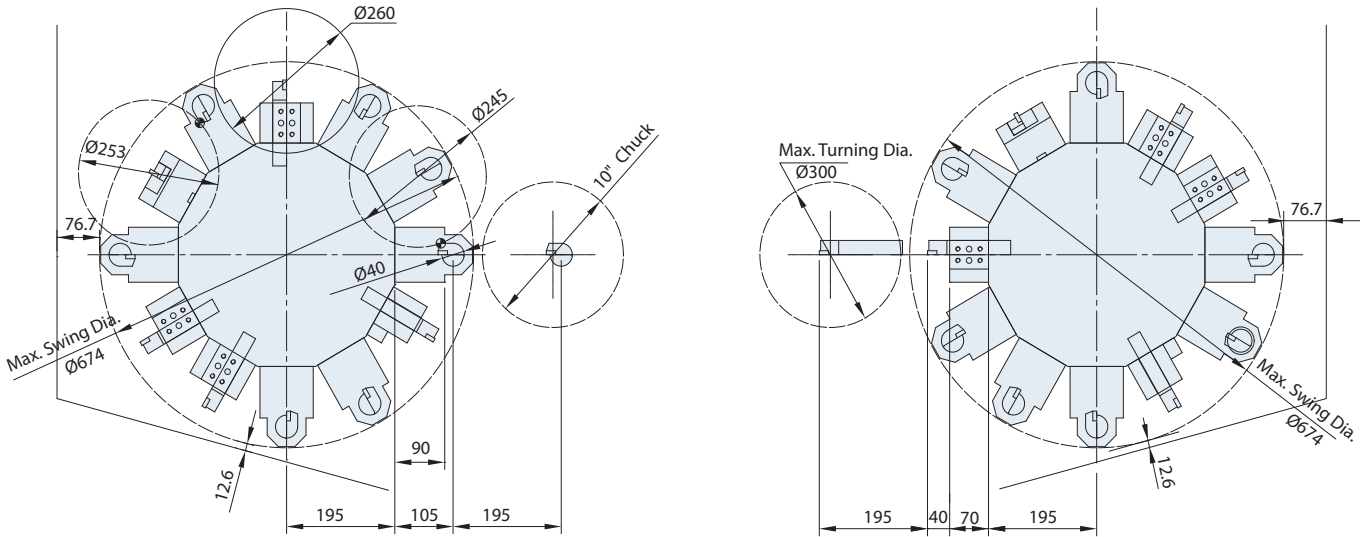

Work Range

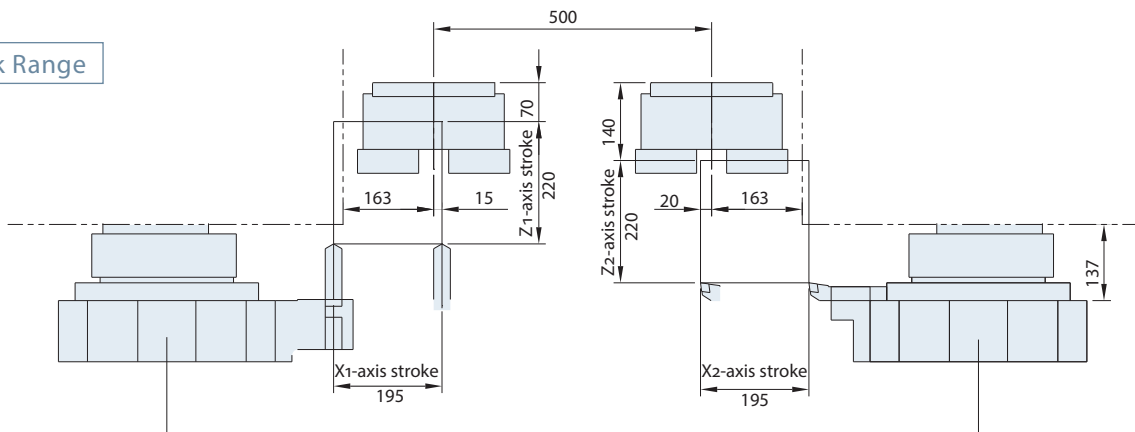

Tooling System

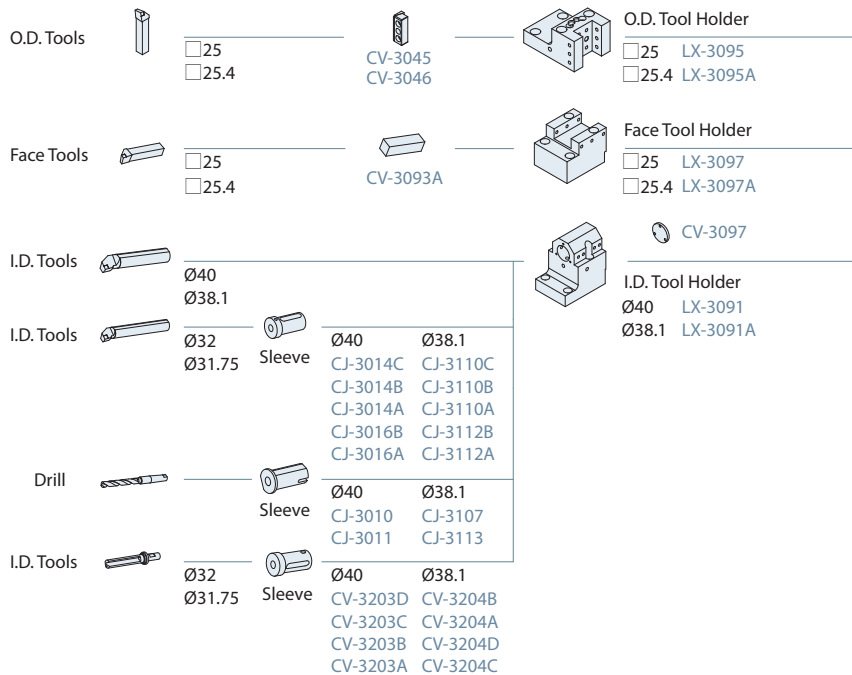

Unit : mm

Interference Diagram 12-Station Live Tooling Turret

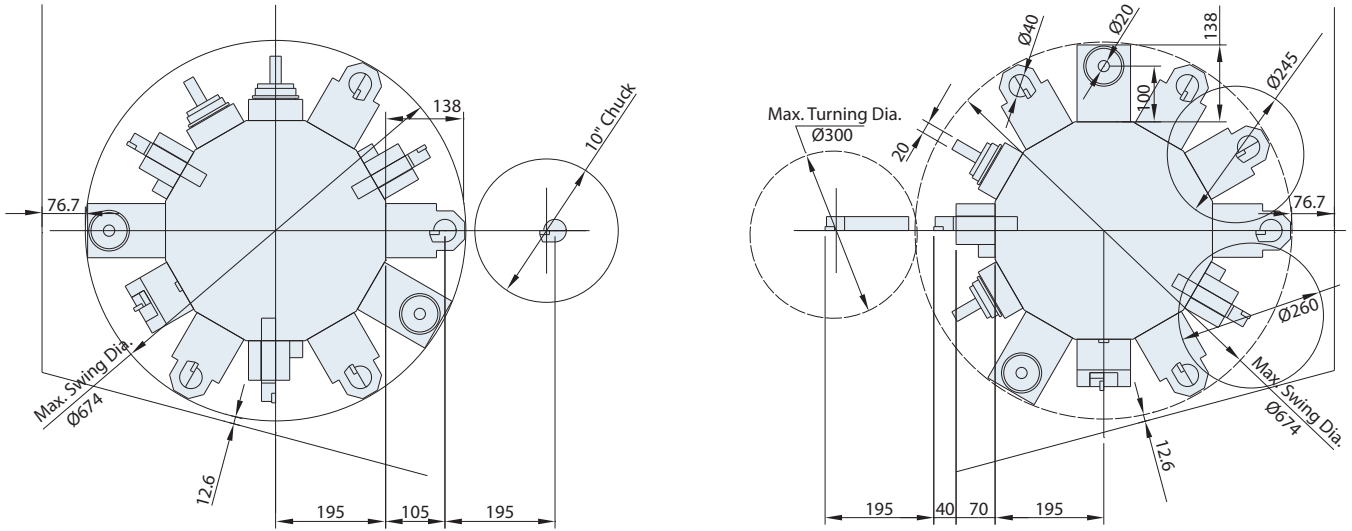

Work Range

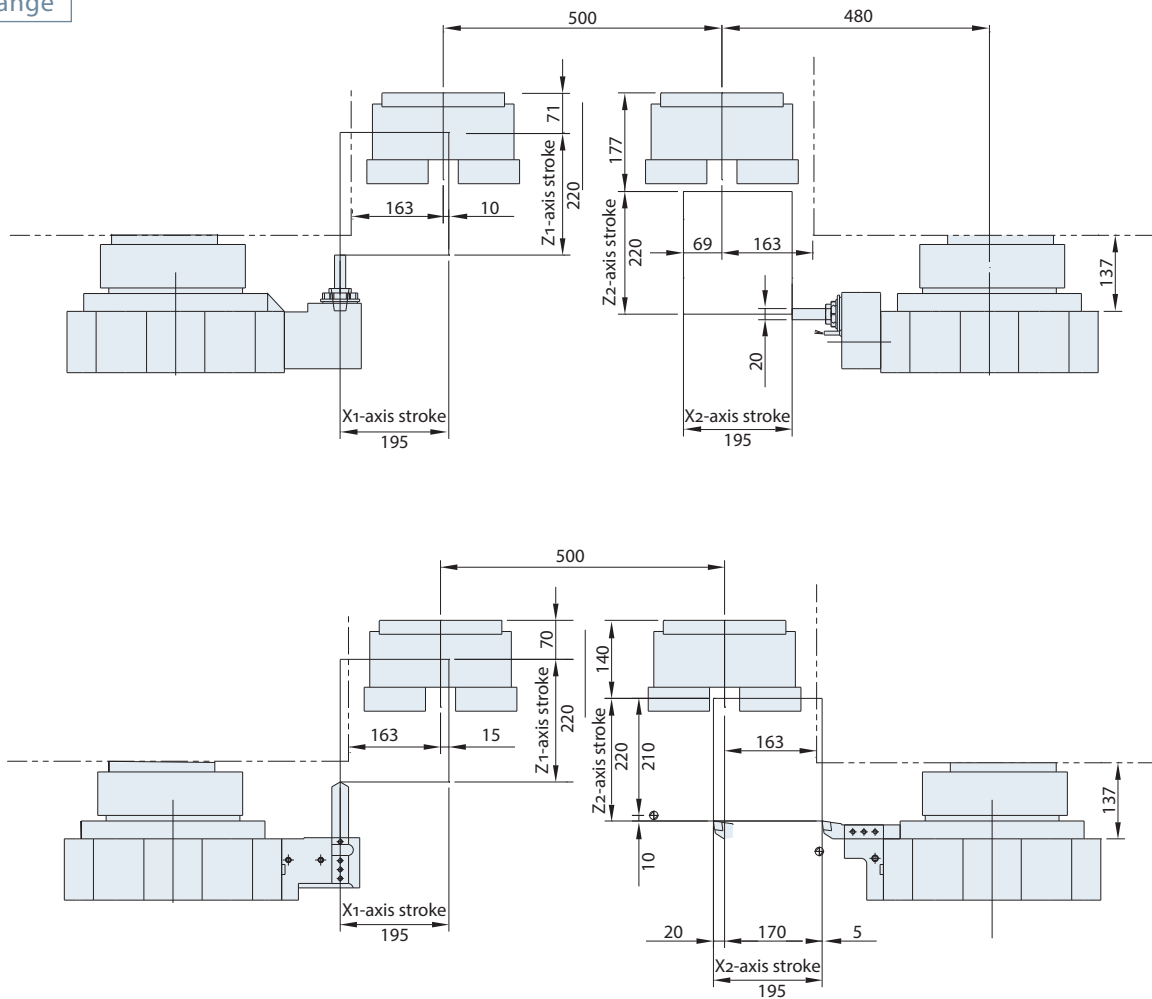

Unit : mm

GENERAL DIMENSION

Tooling System 12-Station Live Tooling Turret

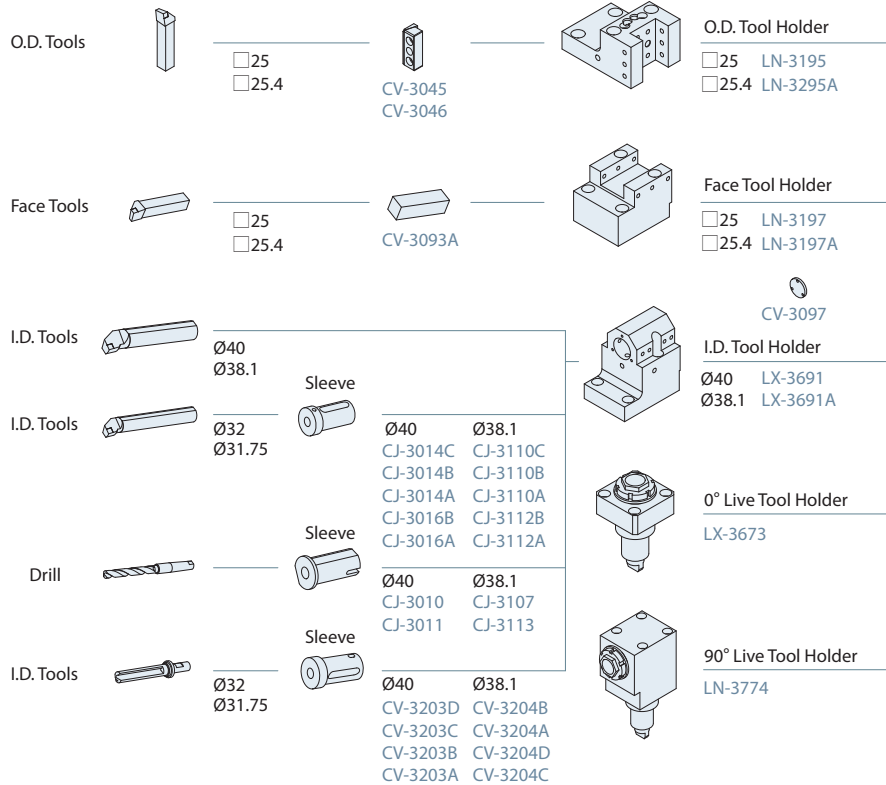

Tooling System 16-Station Live Tooling Turret

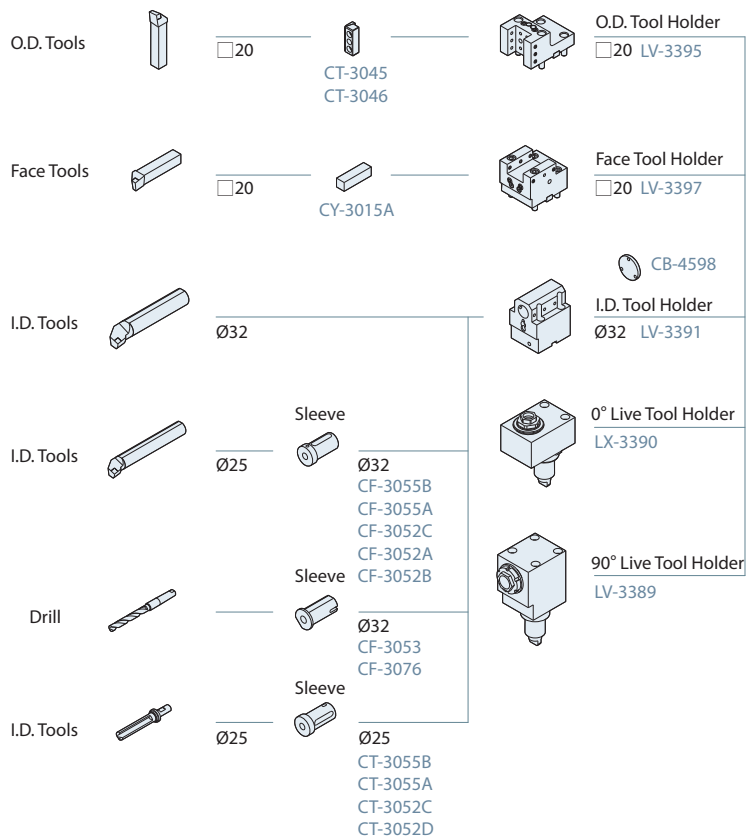

Unit : mm

Interference Diagram 16-Station Live Tooling Turret

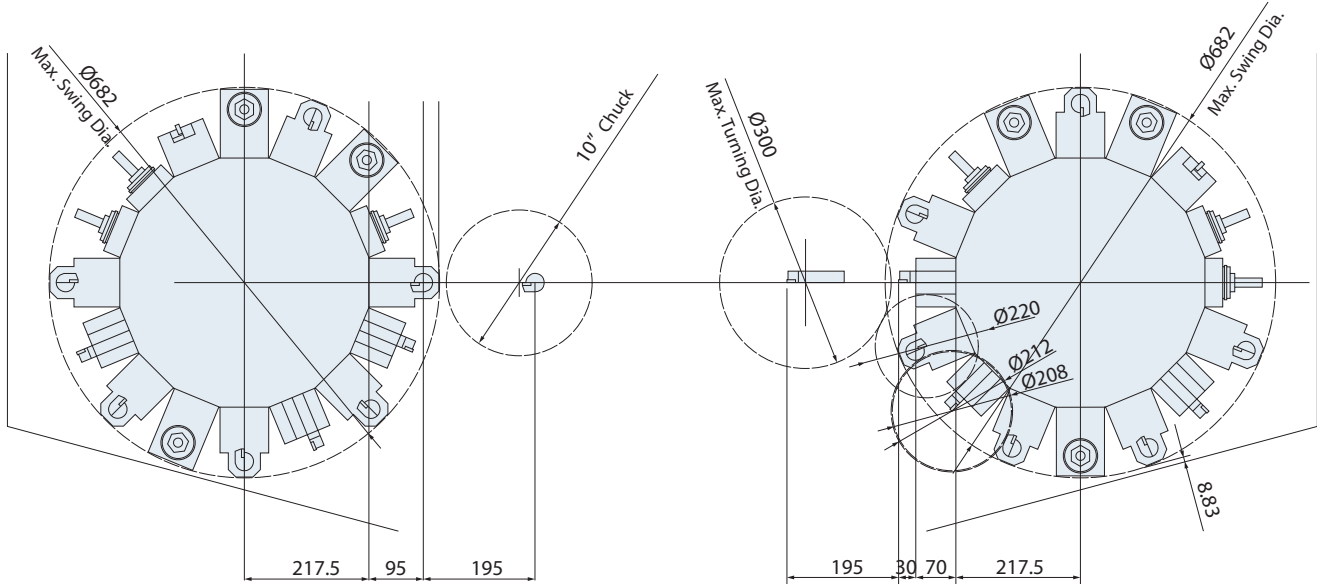

Work Range

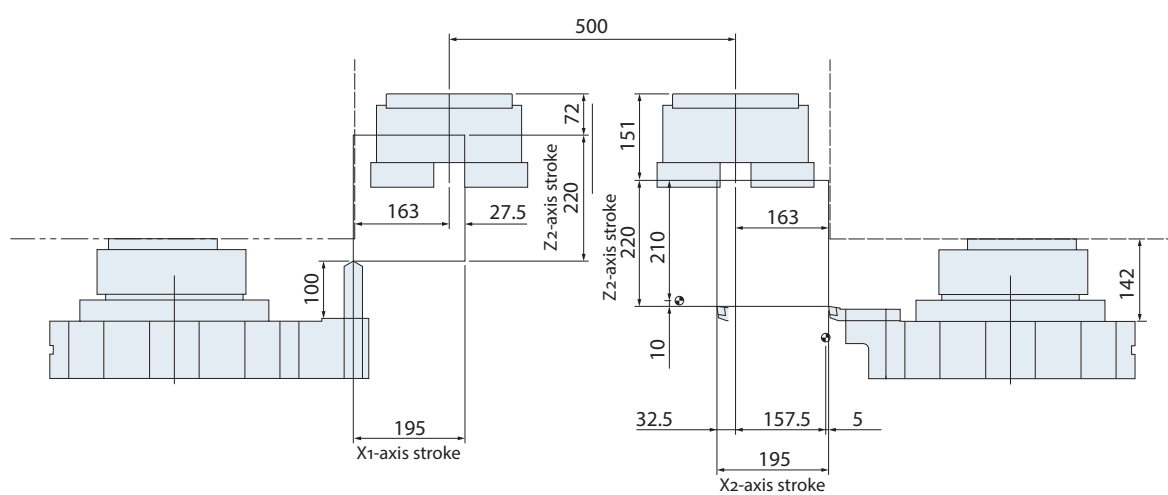
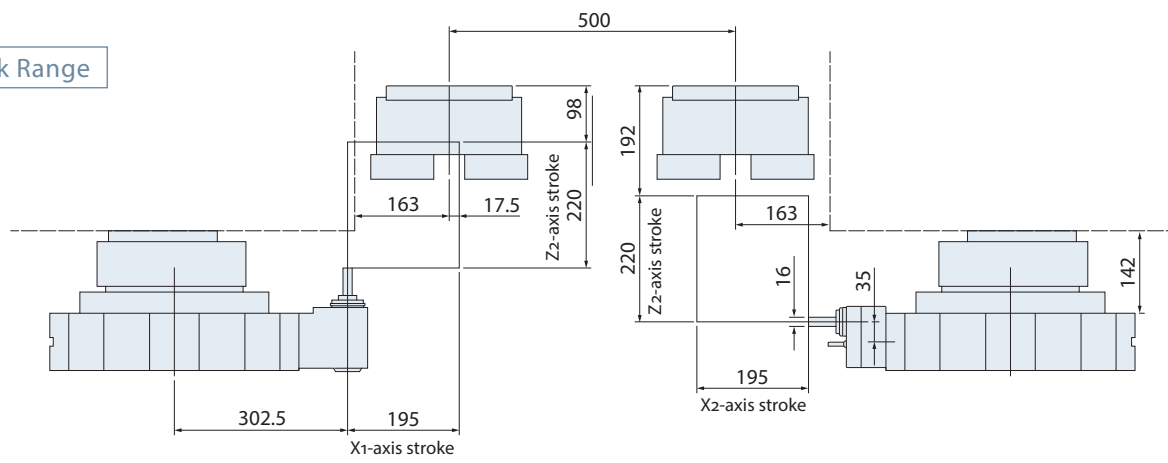

Unit : mm

MACHINE SPECIFICATIONS

CAPACITY		GTH-2000	
Max. turning diameter		Ø 300 mm	11.8"
Standard turning diameter		Ø 260 mm	10.23"
Max. turning length		205 mm	8.07"
Chuck size		10"	
SPINDLE			
Hole through spindle		Ø 66 mm	2.59"
Spindle bearing diameter (Front / Rear)		Ø 100 / Ø 90 mm	3.93" / 3.54"
Spindle nose		A2-6	
Motor output (Cont. / 30 min.)		11 / 15 kW 15 / 20 HP (Opt. 18.5 / 22 kW 25 / 30 HP)	
Motor full output speed		1,500 rpm	
Spindle drive system		Direct Belt Drive	
Spindle drive ratio		7 : 12 (Opt. 17 : 30)	
Spindle speed range		24 ~ 4,000 rpm (Opt. 24 ~ 4,500 rpm)	
Spindle full output speed		875 rpm (Opt. 850 rpm)	
Spindle torque (Cont. / 30 min.)		120 / 162 Nm 88 / 119 lb-ft (Opt. 208 / 247 Nm 153 / 182 lb-ft)	
Cf-AXIS (OPTIONAL)			
Cf-axis motor		AC 1.2 kW	1.6 HP
Cf-axis rapids		33 rpm	
Max. Cf-axis torque (Cont.)		240 Nm 177 lb-ft	
X & Z AXES			
Max. X / Z axes travel		195 / 220 mm	7.67" / 8.66"
X / Z axes rapids		24 m/min.	945 IPM
Slide way type		Box way	
Feed rates		1~ 500 mm/min.	1 ~ 19.6 IPM
X / Z axes servo moter		AC 1.6 / 3 kW	2 / 4 HP
X / Z axes ball screw Ø / pitch		Ø 32 mm	1.25" / Pitch 8
X / Z axes thrust (Cont.)		644 / 958 Kgf 1,420 / 2,110 lbf	
TURRET			
Station		12	
Indexing drive		FANUC AC Servo motor	
Indexing speed		0.2 sec. (Adjacnt) / 0.5 sec. (180° Single step)	
O.D. tool shank size		<input type="checkbox"/> 25 mm 1"	
I.D. tool shank size		Ø 40 mm 1-1/2"	
LIVE TOOLING TURRET (OPTIONAL)			
Max. turning diameter		Ø 300 mm	11.8"
Live tooling stations		12 (Opt. 16)	
Live tooling motor output (Cont. / 30 min.)		AC 3.7 / 5.5 kW 5 / 7.3 HP	
Indexing drive		FANUC AC Servo motor	
Indexing speed		0.2 sec. (Adjacnt) / 0.5 sec. (180° Single step)	
O.D. tool shank size		<input type="checkbox"/> 25 mm 1"	
I.D. tool shank size		Ø 40 mm 1-1/2"	
Live tooling shank size		ER 32 (Ø 20 mm) 3/4"	
Live tooling RPM range		6,000 rpm	

GENERAL	GTH-2000
CNC control	FANUC Oi-TF (Opt. 31 i)
Voltage / Power requirement	AC 220 V / 65 kVA
Hydraulic tank capacity	30 L 7.9 gal
Coolant tank capacity	160 L 42 gal
Machine weight	6,800 Kg 15,000 lb
Dimensions (L x W x H)	4,840 x 2,155 x 3,450 mm 191" x 85" x 136"

Specifications are subject to change without notice.

Space Requirement

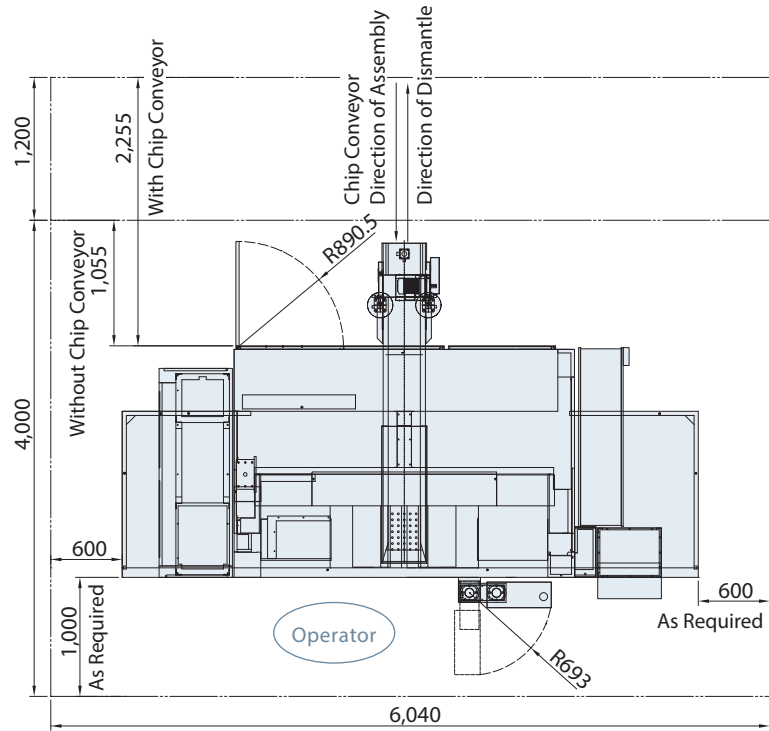

Machine Layout

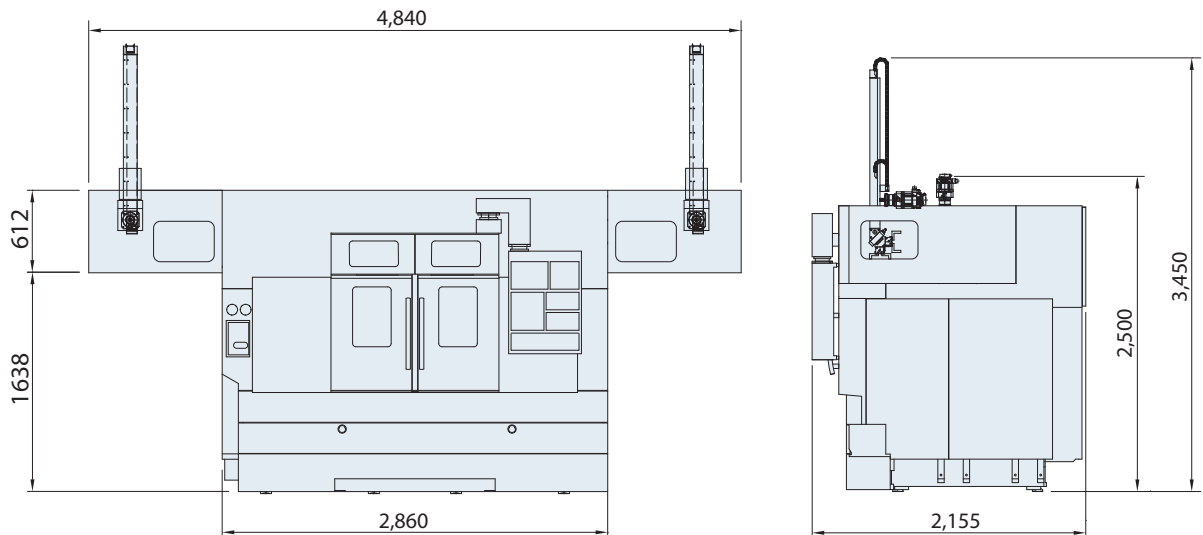

Unit : mm



GOODWAYCNC.com

GOODWAY MACHINE CORP.

HEADQUARTERS

No.13, 5th Road,
Taichung Industrial Park,
Taichung City, 407, Taiwan
E-mail : goodway@goodwaycnc.com

CENTRAL TAIWAN SCIENCE PARK BRANCH

No. 38, Keyuan Road,
Central Taiwan Science Park.Taichung,
Taichung City, 407, Taiwan
TEL : + 886-4-2463-6000
FAX : + 886-4-2463-9600

GOODWAY MACHINE (WUJIANG) CO.,LTD

No. 4888, East Lake Taihu Avenue, Wujiang
Economic and Technological Development Zone,
Jiangsu, China
Sales Hotline : + 86-512-8286-8068
Service Hotline : + 86-512-8286-8066
FAX : + 86-512-8286-8620
E-mail : goodway@goodwaycnc.cn