

correa

# XPERTA | NORMA

Bed type milling machine

WARRANTY



The **NORMA** represents a new concept in fixed frame, lateral ram machine. Very sturdy thanks to structural elements with large sections together with an L-shaped ram guide system. A high precision thanks to the mechanical ram droop correction system. A flexible machine suitable for machining and finishing operations.



L-GUIDE-WAY SYSTEM CONFIGURATION

- L-shaped guide system:
  - Greater rigidity and stability during machining.
  - Greater geometrical precision.
  - Less ram droop effect.
- 6 vertical movement sliders ensuring good machine behaviour.

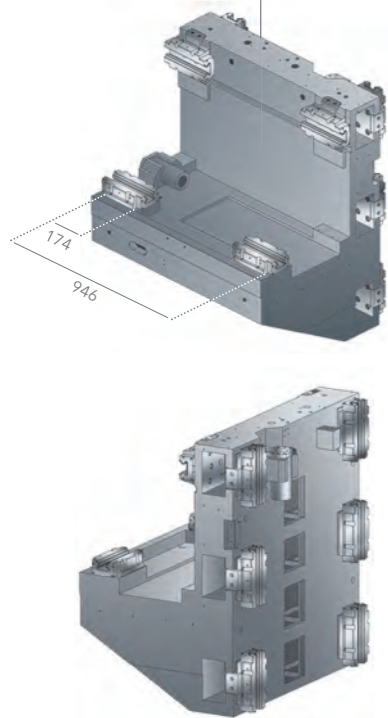

MORE ABOUT THE NORMA



Dynamic performance parametrizable in accordance with:

- ROUGHING OPERATION
- FINISHING OPERATION



MACHINE DYNAMIC ADJUSTMENT

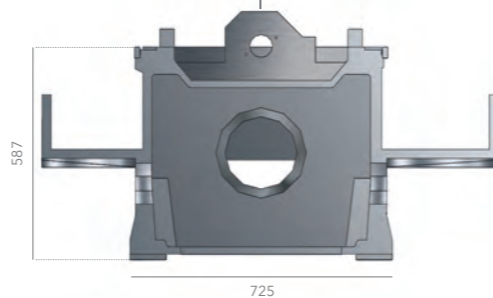

MECHANICAL COMPENSATION SYSTEM

Traction bars to eliminate the angular error of the ram droop effect

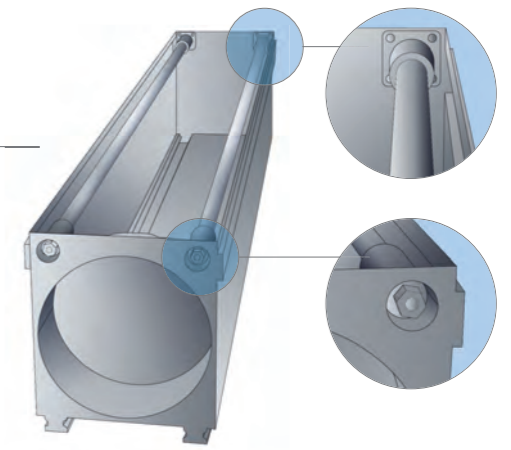

The largest cross-sections on the market.  
High machining capacity + geometrical stability over time.



OVERSIZED STRUCTURAL ELEMENTS



HIGH GEOMETRICAL PRECISION



25 m/min in X, Y and Z axes, thanks to its V-Shaped linear guide-ways in all axes



HIGH FEED RATES



ECO DESIGN

Stand-by function and Auto Switch off function, saving 20% of the total energy machine consumption

## Technical Features

NORMA 20    NORMA 25    NORMA 35    NORMA 45

### TABLE

|                           |             |             |             |             |    |
|---------------------------|-------------|-------------|-------------|-------------|----|
| Surface                   | 2300 x 1000 | 2800 x 1000 | 3800 x 1000 | 4800 x 1000 | mm |
| Maximum load on the table | 4500        | 6500        | 8500        | 10500       | kg |

### TRAVERSES

|                  |      |      |      |      |    |
|------------------|------|------|------|------|----|
| Longitudinal [X] | 2000 | 2500 | 3500 | 4500 | mm |
| Cross [Y]        | 1250 |      |      |      | mm |
| Vertical [Z]     | 1500 |      |      |      | mm |

### FEEDS

|             |    |  |  |  |       |
|-------------|----|--|--|--|-------|
| Maximum [X] | 25 |  |  |  | m/min |
| Maximum [Y] | 25 |  |  |  | m/min |
| Maximum [Z] | 25 |  |  |  | m/min |

### SPINDLE SPECIFICATIONS

|                    |                           |  |  |  |     |
|--------------------|---------------------------|--|--|--|-----|
| Spindle nose       | ISO-50 Big Plus / HSK-100 |  |  |  |     |
| Programmable speed | 4000 / 6000               |  |  |  | rpm |
| Maximum power      | 24 / 33                   |  |  |  | kW  |
| Maximum torque     | 840 / 990                 |  |  |  | Nm  |

### WEIGHT

|                |       |       |       |       |    |
|----------------|-------|-------|-------|-------|----|
| Machine weight | 17800 | 19000 | 21200 | 24000 | kg |
|----------------|-------|-------|-------|-------|----|

## External Dimensions

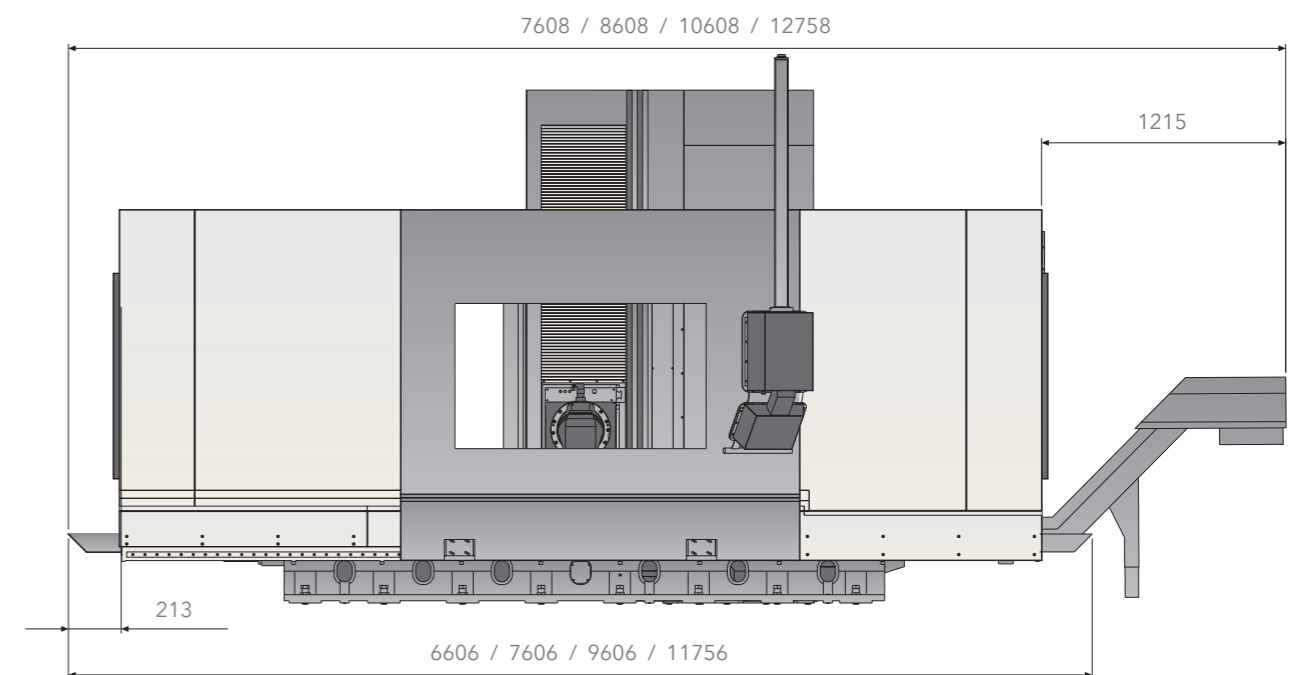
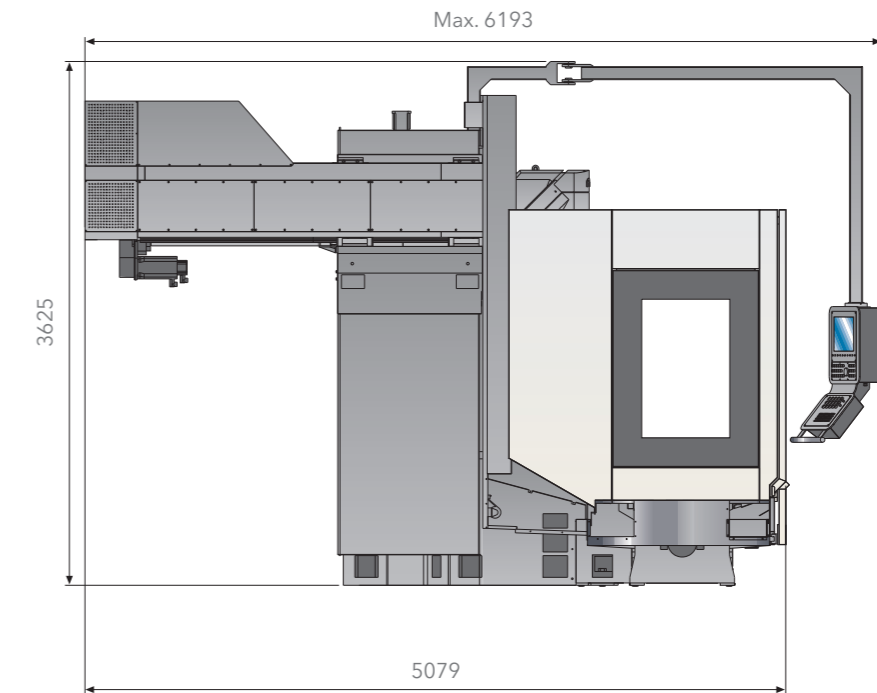

# NORMA

Bed type milling machine



## Technical Features

XPERTA 20
XPERTA 25
XPERTA 35
XPERTA 45

### TABLE

|                           |             |             |             |             |    |
|---------------------------|-------------|-------------|-------------|-------------|----|
| Surface                   | 2300 x 1000 | 2800 x 1000 | 3800 x 1000 | 4800 x 1000 | mm |
| Maximum load on the table | 4500        | 6500        | 8500        | 10500       | kg |

### TRAVERSES

|                  |      |      |      |      |    |
|------------------|------|------|------|------|----|
| Longitudinal [X] | 2000 | 2500 | 3500 | 4500 | mm |
| Cross [Y]        | 1000 |      |      |      | mm |
| Vertical [Z]     | 1000 |      |      |      | mm |

### FEEDS

|             |    |  |  |  |       |
|-------------|----|--|--|--|-------|
| Maximum [X] | 25 |  |  |  | m/min |
| Maximum [Y] | 25 |  |  |  | m/min |
| Maximum [Z] | 25 |  |  |  | m/min |

### SPINDLE SPECIFICATIONS

|                    |                           |  |  |  |     |
|--------------------|---------------------------|--|--|--|-----|
| Spindle nose       | ISO-50 Big Plus / HSK-100 |  |  |  |     |
| Programmable speed | 4000 / 6000               |  |  |  | rpm |
| Maximum power      | 24                        |  |  |  | kW  |
| Maximum torque     | 840                       |  |  |  | Nm  |

### WEIGHT

|                |       |       |       |       |    |
|----------------|-------|-------|-------|-------|----|
| Machine weight | 15200 | 16400 | 18600 | 22000 | kg |
|----------------|-------|-------|-------|-------|----|

## External Dimensions

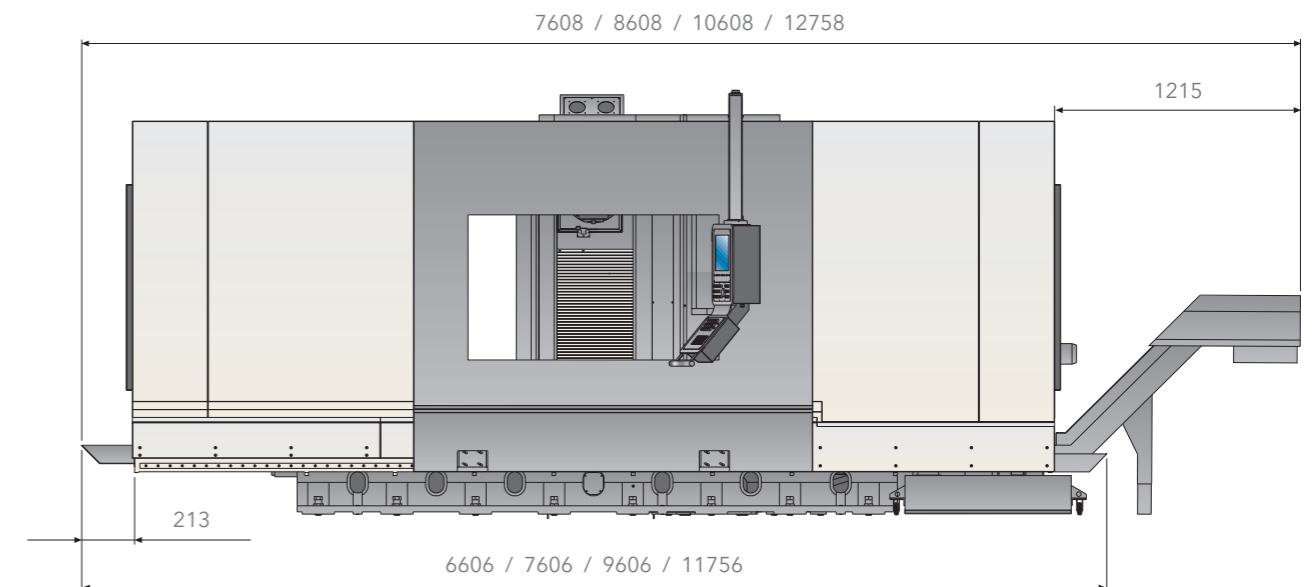
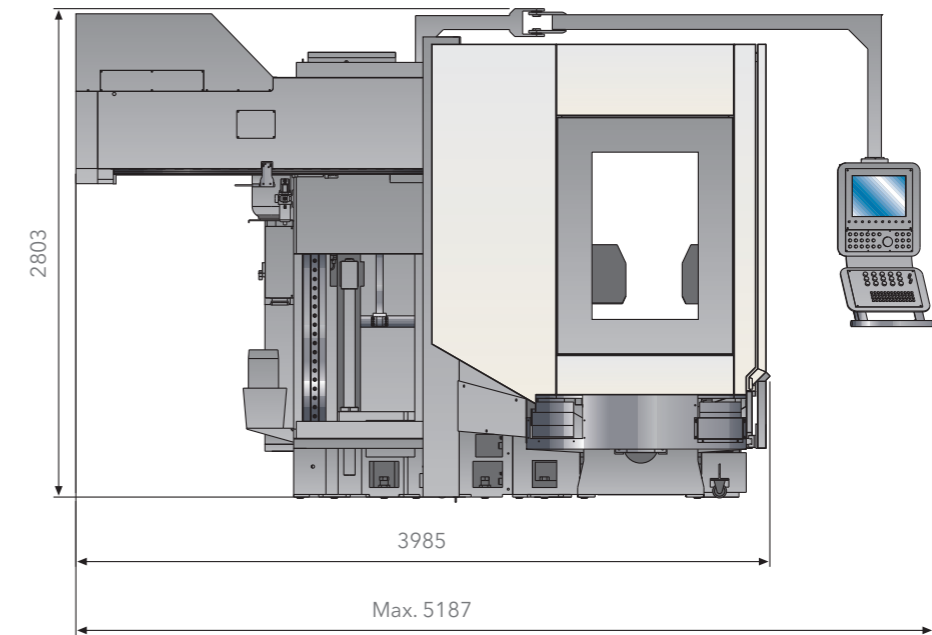



## Milling Head

### NORMA



#### UAD 0.02° x 0.02°

Universal Auto-Indexing  
Differential Head  
24 kW | 840 Nm | 6000 rpm  
33 kW | 990 Nm | 6000 rpm



#### OAD 0.02° x 0.02°

Orthogonal Auto-Indexing  
Differential Head  
24 kW | 840 Nm | 6000 rpm  
33 kW | 990 Nm | 6000 rpm

#### UDG 2.5° x 2.5°



Universal Automatic Head  
24 kW | 840 Nm | 4000 rpm  
33 kW | 990 Nm | 4000 rpm

### XPERTA



#### UAD 0.02° x 0.02°

Universal Auto-Indexing  
Differential Head  
24 kW | 840 Nm | 6000 rpm



#### UDG 2.5° x 2.5°

Universal Automatic Head  
24 kW | 840 Nm | 4000 rpm

## Standard Equipment

Automatic Universal Head • Vixion 4.0

Numerical control Heidenhain TNC 640 • Gearbox

Portable handwheel • Hydraulic group

Air-conditioned electrical cabinet • Linear scales in all axes

Linear guides in the X, Y and Z axes • External Coolant with adjustable nozzles in the head

Lamp in the working area • Perimeter fence

Direct Tele-service

## Optional Equipment

Other heads • Centrifugal filter in cutting fluid tank

Pick up station for 8 tools • Air or oil cleaning gun with motor pump

Automatic charger for 30, 40 and 60 tools • Coolant through spindle to high and medium pressure

Probes of measurement, tools and parts • Chip conveyors

Rotary tables • Integral guarding

Basic guarding

# correa

[www.nicolascorrea.com](http://www.nicolascorrea.com)

## **GNC Hypatia**

Condado de Treviño, 53  
09001 Burgos • Spain  
Phone: +34 947 298 528  
Fax: +34 947 473 520  
[info@gnchypatia.com](mailto:info@gnchypatia.com)

## **Nicolás Correa, S.A.**

Alcalde Martín Cobos, 16-A  
09007 Burgos • Spain  
Phone: +34 947 288 100  
Fax: +34 947 288 117  
[correa@correa.es](mailto:correa@correa.es)

